



Meet The Reinvention of the Wheel

The Patriot Line of Poly-U® wheels is proud to introduce the Patriot Plus Friction wheel. A wheel designed to meet and exceed current and future shopping cart wheel demands.

Key Wheel Features

- Easy Rolling
- Smooth and Quiet
- User Friendly
- Load Capacity 250 pounds

A Friction Shopping Cart Wheel Designed to Keep Your Carts Rolling and Your Customers Satisfied

POLY-U® PRECISION QUAD X PLUS BEARING SYSTEM FEATURES

- Reduce Parking Lot Damage Claims
- Maintenance Free Friction Solution
- No Adjustments Required
- Long Lasting Friction
- Patented Poly-U® Friction Precision Bearing Design
- Smooth and Quiet Rolling
- User Friendly and Safe
- Installs Like a Standard Shopping Cart Wheel

The Poly-U® Patriot Plus FRICTION Wheel



Comparison Test Between Standard Shopping Cart Wheels and FRICTION Wheels

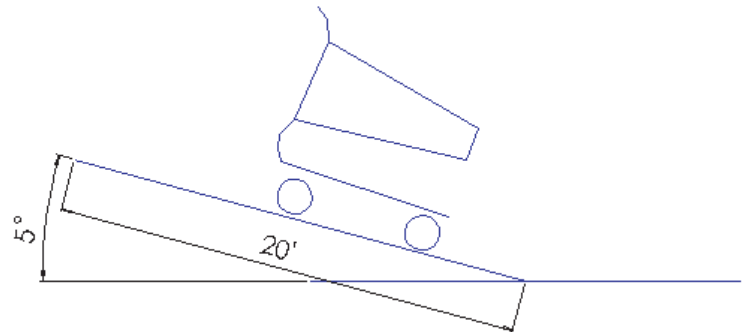

Relationship between distance and speed on a slope of about 5°

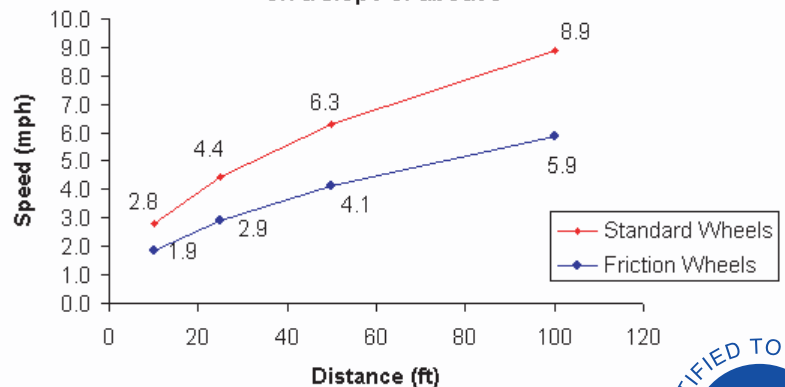

To Order the Poly-U® Patriot Plus FRICTION Wheel, Please Call:
 Toll Free 1-800-354-8622
 Phone 817-468-3850 • Fax 817-468-2850
 1208 N. Commercial Blvd • Arlington, TX 76001
www.phcasters.com
info@phcasters.com

